

T-7182 NEEDLE SCALER T-7182A WELD FLUX SCALER

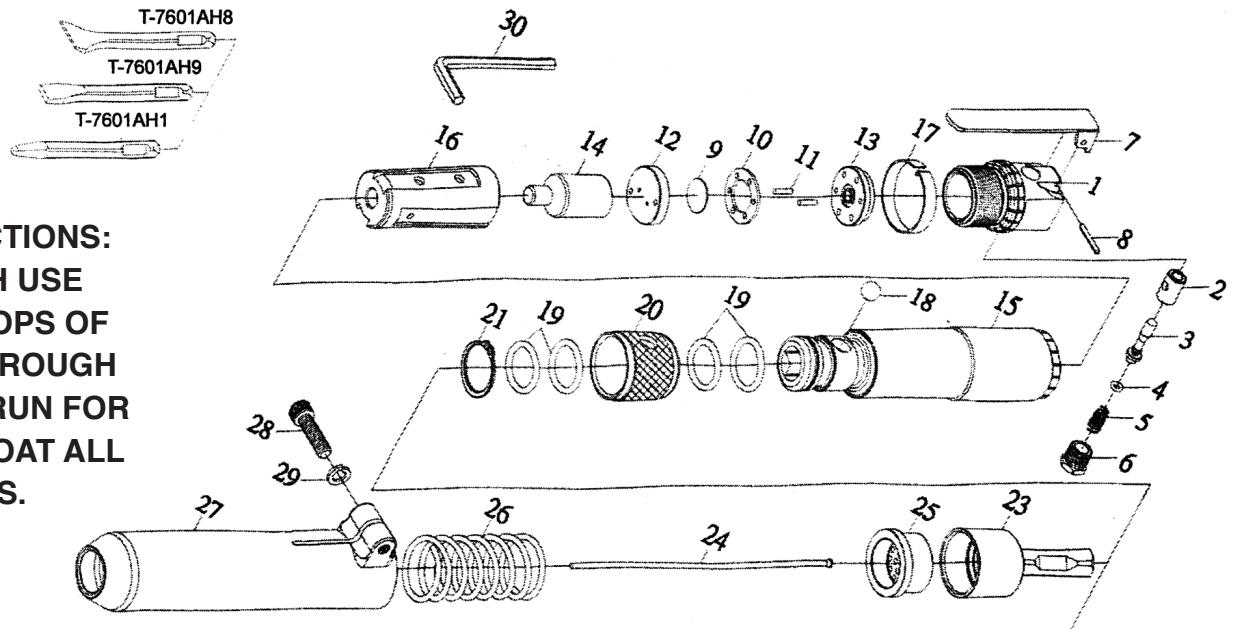

OILING INSTRUCTIONS:
OIL AFTER EACH USE
WITH A FEW DROPS OF
AIRTOOL OIL THROUGH
THE AIR INLET. RUN FOR
1 SECOND TO COAT ALL
INTERNAL PARTS.

***USING PRESSURE GREATER THAN 90 PSI MAY
CAUSE HEAVY WEAR AND WILL VOID WARRANTY.**

USE 90 PSI MAXIMUM

REF #	PART #	DESCRIPTION	QTY	REF #	PART #	DESCRIPTION	QTY
1	718201	BACK HEAD	1	19	718219	O-RING	4
2	718202	THROTTLE BUSHING	1	20	718220	CHISEL COVER	1
3	718203	VALVE STEM	1	21	718221	SNAP RING	1
4	718204	O-RING	1	23	718223	NEEDLE DRIVER	1
5	718205	SPRING	1	24	718224	SET OF 19 NEEDLES	1set
6	718206	THROTTLE CAP	1	25	718225	NEEDLE HOLDER	1
7	718207	THROTTLE LEVER	1	26	718226	SPRING	1
8	718208	SPRING PIN	1	27	718227	TUBE	1
9	718209	FLIPPER VALVE	1	28	718228	CAP HEAD SCREW	1
10	718210	VALVE SPACER	1	29	718229	WASHER	1
11	718211	PIN	2	30	718230	HEX WRENCH	1
12	718212	LOWER VALVE	1			OPTIONAL ACCESSORIES	
13	718213	UPPER VALVE	1			T-7601AH8	1-1/4" ANGLE CHISEL
14	718214	PISTON	1				(COMES WITH 7182A)
15	718215	CYLINDER	1			T-7601AH9	3/4" COLD CHISEL
16	718216	PISTON SLEEVE	1			T-7601AH1	DIAMOND POINT CHISEL
17	718217	LOCK RING	1				
18	718218	BALL	1				